



Lifting 700kg at 1.1m, the 700s, displays Australian quality and design standards



***700Kg Lifting Capacity At 1.1M
2.8 Metre Full Extension
270Kg Lifting Capacity At 2.8M
Emergency Stop
Slew Operator Protection
Hose Burst Protection
Valve Control Guard
Load Indicator
Compliance - AS1418-11-2014***

***Flexible Mounting Options
Purposely built for the Australian Market
National and International Dealer Network
Specialised Attachments Available
Proudly Australian Made
2 Year Warranty
5 Year Limited Warranty***



KEVREK 700s CRANE SPECIFICATIONS

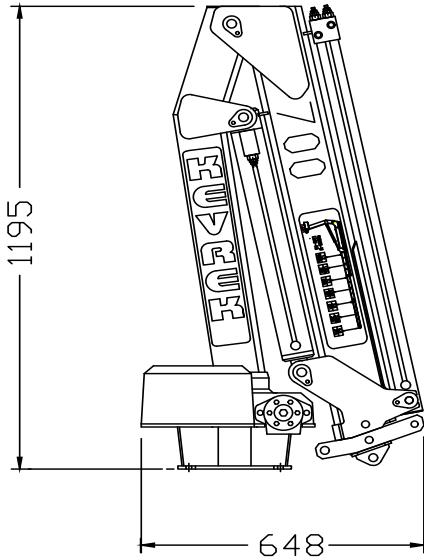

TECHNICAL FEATURES:

Capacity Class	0.75 Tm (7.35 kNm)
Maximum Lift Capacity	700kg @ 1.12m Radius
Standard Outreach	1.95m
With Additional Boom	2.83m
Lifting Height Above Base Standard	2.90m
With Additional Boom	3.80m
Outreach/Lifting Capacity	1.10m - 700kg 1.68m - 450kg 2.28m - 340kg 2.83m - 270kg
Slewing Torque	1.5 kNm
Slewing Angle	290°
Pump Capacity	4.9 > 7.0l/min
Oil Tank Volume	3.0l
Working Pressure	1750 PSI (120 BAR)
Power Consumption	12 volt 50 > 150 amp 24 volt 50 > 90 amp
Weight Inc/Power Pack And Oil	152kg
Weight - Manual Leg C/W Motor Mount and Storage Mount	18kg
Swing up Hydraulic Stabiliser Leg	43kg
Height Folded	1195mm

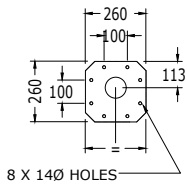

MOUNTING BASE PATTERN

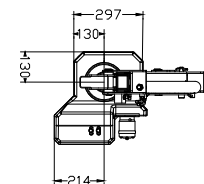

Options:

- Radio Remote Control
- Manual Swing Up Leg
- Hydraulic Leg
- Multiple Function Pendant Control
- 350Kg Hydraulic Winch C/W 15m Cable

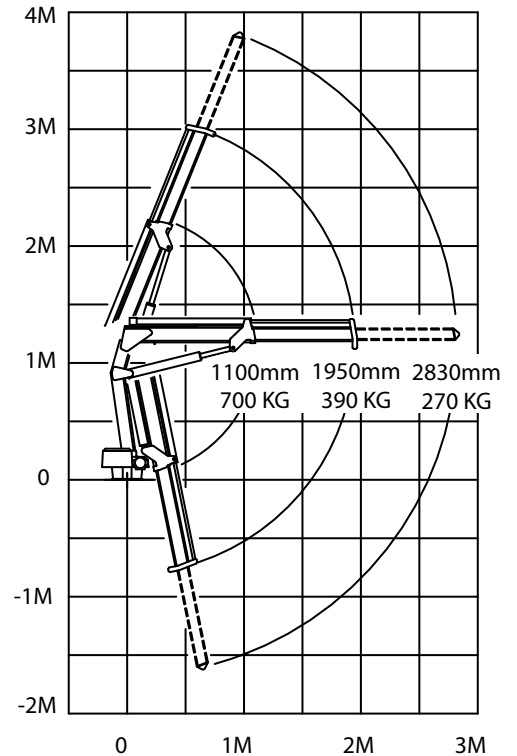
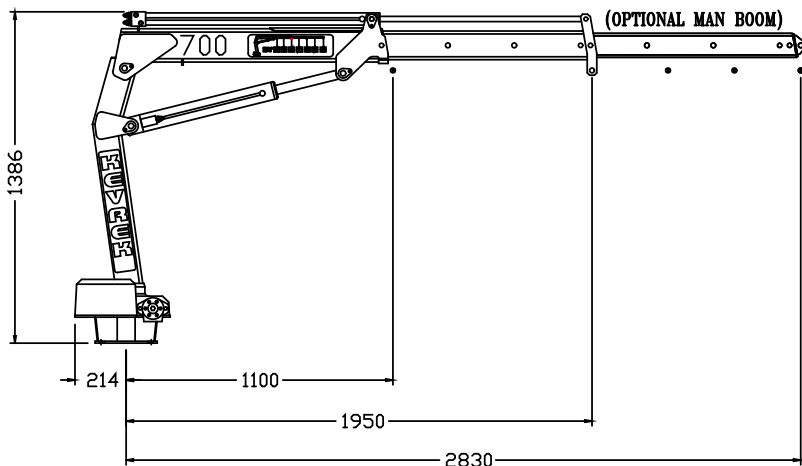

The Australian Lifting Solution



156 Beringarra Ave, MALAGA WA 6090
 email: kevrek@kevrek.com.au
 website: www.kevrek.com.au
 Ph: (08) 9248 5922 Fax: (08) 9248 5966

Kevrek Australia reserves the right to discontinue models or options at any time or change specifications, materials, equipment, or pricing without notice and without incurring obligation.