

F10X™

MIRAGE

Introducing the NEW RICON® Mirage® F10X™ Wheelchair lift

The Mirage F10X provides
maximum baggage space
automatic convenience and the
security of the Ricon Safety Zone.



THE INDUSTRY STANDARD FOR OVERALL PERFORMANCE, RELIABILITY & VALUE

The Ricon Mirage F10X is the only low-profile motorcoach wheelchair lift providing maximum space efficiency, automatic convenience and the security of the Ricon Safety Zone. The exclusive, floor-mounted F10X cassette design yields a large, horizontal luggage bay area that enables drivers to quickly load more suitcases and larger parcels from both the curb and the street side of the coach. With the press of a button the Mirage F10X automatically deploys, lowers, raises and stows - the latest innovative example of why Ricon Corporation is the world leader in motorcoach accessibility.

PERFORMANCE, RELIABILITY AND VALUE

The Ricon Mirage F10X motorcoach wheelchair lifts provide secure and reliable access while setting the industry standard for safety, performance, value and ease of use. These innovative lightweight designs feature:

- Easy operation and maintenance
- Multiple dimension options providing versatility between customers
- Floor-mounted design uses less than one cubic metre
- Mid-coach mounting optimizes load and off-load time
- Horizontal cassette provides even weight distribution
- Patented interlocked occupant restraint belt system
- Rated 300 kg load capacity
- Industry leading 2-year parts and labor warranty

F10X™

MIRAGE

ADVANCED RICON LIFT TECHNOLOGY FEATURES RELIABLE PERFORMANCE AND USER-FRIENDLY DESIGN.

Features:

- Low-profile cassette design for minimizing impact on luggage bays.
- Floor-mounted design uses less than one metre³.
- Mid-coach mounting optimizes load and off-load time.
- Horizontal cassette provides even weight distribution.
- Easy to use automatic push-button operation.
- Industry-leading Ricon Safety Zone, combines front and rear roll stops and handrails, secures passengers during lift operation.
- Simple and reliable operation provides convenient vehicle access for wheelchairs.
- Multiple dimension options available providing versatility between customers.
- Standard lifts rated at 300kg.
- ADA regulation compliant.
- 2-year Limited Warranty.



EXCLUSIVE DURA-TOUCH CONTROL PENDANT – Tough and versatile new pendant features shock-resistant polypropylene case with bumper edges, water-resistant buttons and heavy-duty coiled cord.

MANUAL BACKUP SYSTEM – hand pump mechanism provides manual lift operation in case of power loss.

RICON STO-LOC™ – features quiet patented Sto-Loc mechanism securing the lift when stowed.

HYDRAULIC POWER PACK - Hydraulic power provided by remotely located Hydraulic Power Pack.

OCCUPANT RESTRAINT SAFETY SYSTEM –Patented fully interlocked Ricon occupant restraint belt system. Combines with dual handrails, inner and outer roll-stop barriers and side rails for industry-leading passenger security.

LIFT WEIGHTS – rated at 300kg.

COMPLIANT WITH APPLICABLE STANDARDS -

- AS 3856 (Part 1&2):1998

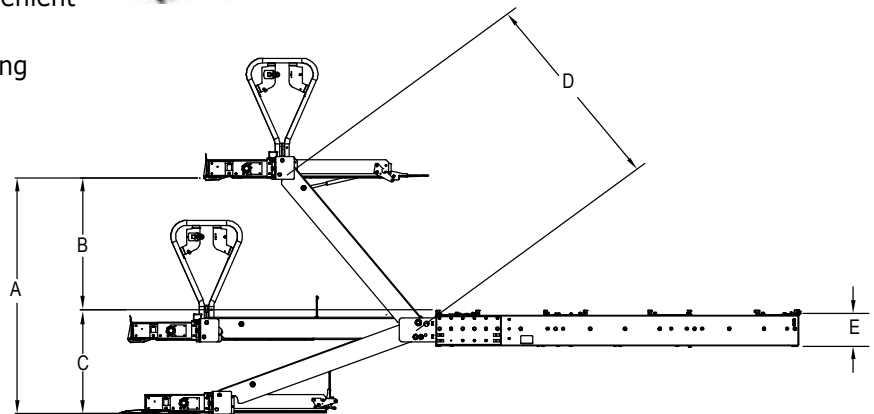

Mirage™LIFT: Model FX10

Power Under 1,500 Watts at 24 Volts DC
 Pump rating 1800 psi/ 12.4MP
 Hydraulic Cylinder ... Duel, Single Acting 3.0"/ 76 mm
 With Integrally-Mounted Flow Control Devices
 Rated load capacity300 kg
 Volume of Stowed Lift0.69M³

DIMENSIONS - mm	A ¹	B ¹	C ¹	D	E	F
MODEL	Max Floor to ground Travel	Max Travel Above Enclosure	Max Travel Below Enclosure	Arm Length	Enclosure Height	Enclosure Width
F10X	1560	879	678	1339	239	1252

G ²	H	I	J	K	L
Enclosure Length	Usable Platform Length	Usable Platform Width	Traveling Frame Width	Handrail Height	Bridge Plate Height
2311	1219	762	1168	762	310

1. Additional travel is possible up to the following maximums pending applications engineering:
 A=1829 mm; B 902mm; C 1029mm
2. The overall length of the unit is slightly longer than the enclosure length but the amount of the Sto-Loc™ hook extends beyond the front end of the enclosure 19.5mm when the lift is stowed

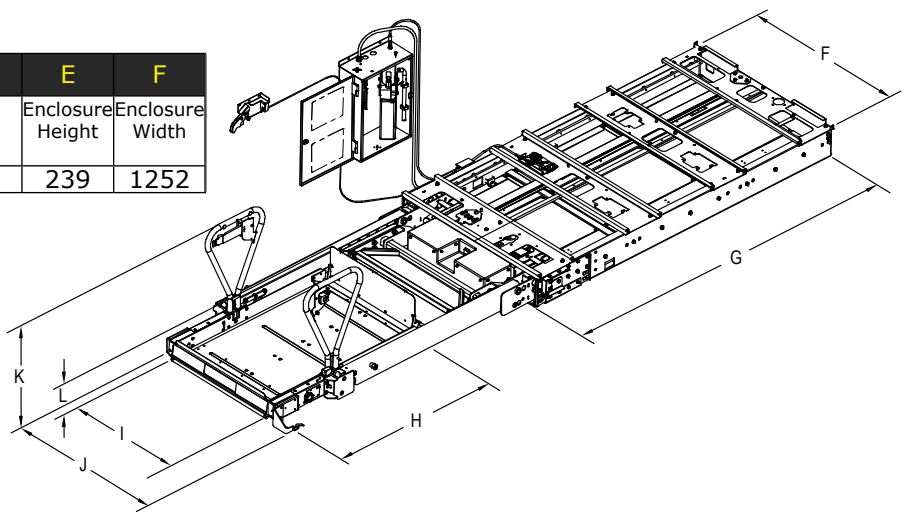

National Importer and Distributor



156 Beringarra Ave, MALAGA WA 6090
 email: kevrek@kevrek.com.au
 website: www.kevrek.com.au
 Ph: (08) 9248 5922 Fax: (08) 9248 5966

Copyright 2010 Ricon Corporation. Ricon, Mirage, F10X and Sto-Loc are trademarks of Ricon Corporation. Ricon Corp and Kevrek Australia reserves the right to discontinue models or options at any time or change specifications, materials, equipment, or pricing without notice and without incurring obligation.

