

## Introducing the Commercial High Floor Baylift™ Wheelchair Lift

The safety, reliability and uniqueness of the Baylift™ combine to make the ideal solution for your dedicated entry needs.



### THE INDUSTRY STANDARD FOR OVERALL PERFORMANCE, RELIABILITY & VALUE

Ease of operation and space-efficient design make the Ricon BayLift™ wheelchair lift a motorcoach industry favorite. The compact BayLift configuration requires only 18 inches of luggage bay depth so it fits where other lifts cannot. The durable steel construction assures years of trouble-free operation, while the unique design ensures routine maintenance requires minimal time and effort.

### PERFORMANCE, RELIABILITY AND VALUE

Ricon Baylift™ wheelchair lifts provide secure and reliable access while setting the industry standard for safety, performance, value and ease of use. These innovative designs feature:

- Easy operation and maintenance
- Durable steel design for long lift life
- Multiple dimension options providing versatility between customers
- Interlocking passenger safety restraint belt.
- One year limited warranty

## ADVANCED RICON LIFT TECHNOLOGY FEATURES RELIABLE PERFORMANCE AND USER-FRIENDLY DESIGN.

### Features:

- 1575mm vertical travel makes high floor bus access easy.
- Compact frame extends only 458mm into the luggage bay.
- Mid-coach mounting optimizes load and off-load time.
- Easy to use automatic push-button operation
- Durable steel design for long lift life.
- Easy operation and maintenance.
- Industry-leading Ricon Safety Zone, combines front and rear roll stops and handrails, secures passengers during lift operation.
- Simple and reliable operation provides convenient vehicle access for wheelchairs.
- Multiple dimension options available providing versatility between customers.
- Standard lift rated at 272kg.
- 1 year Limited Warranty.

### COMPLIANT WITH APPLICABLE STANDARDS -

- AS 3856 (Part 1&2):1998

### Baylift™: Model SSBF

Power ..... Electro - Hydraulic  
 Pump rating @ 24V DC.... 65 amp avg./cycle 1800 psi  
 Hydraulic Cyl ..(2) Ø1.75" Single Acting/Gravity Down  
 Manual Backup (up)..... Hand Pump  
 Manual Backup (down)..... Pressure Release Valve  
 Rated load capacity ..... 272 kg  
 Lift Weight..... 268kg

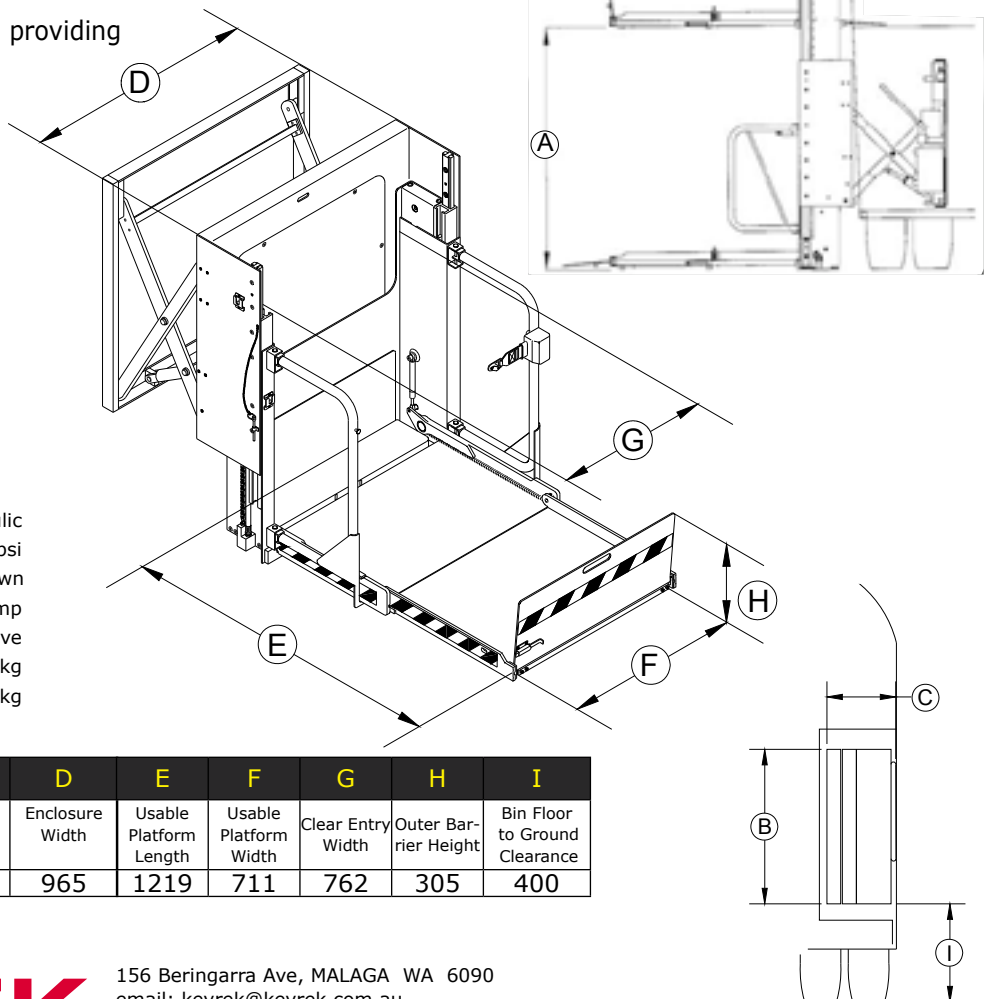

| DIMENSIONS - mm | A                          | B                | C                | D               | E                      | F                     | G                 | H                    | I                             |
|-----------------|----------------------------|------------------|------------------|-----------------|------------------------|-----------------------|-------------------|----------------------|-------------------------------|
| <b>MODEL</b>    | Max Floor to ground Travel | Enclosure Height | Enclosure Length | Enclosure Width | Usable Platform Length | Usable Platform Width | Clear Entry Width | Outer Barrier Height | Bin Floor to Ground Clearance |
| <b>SSBF</b>     | 1575                       | 940              | 457              | 965             | 1219                   | 711                   | 762               | 305                  | 400                           |

### National Importer and Distributor



156 Beringarra Ave, MALAGA WA 6090  
 email: kevrek@kevrek.com.au  
 website: www.kevrek.com.au  
 Ph: (08) 9248 5922 Fax: (08) 9248 5966